

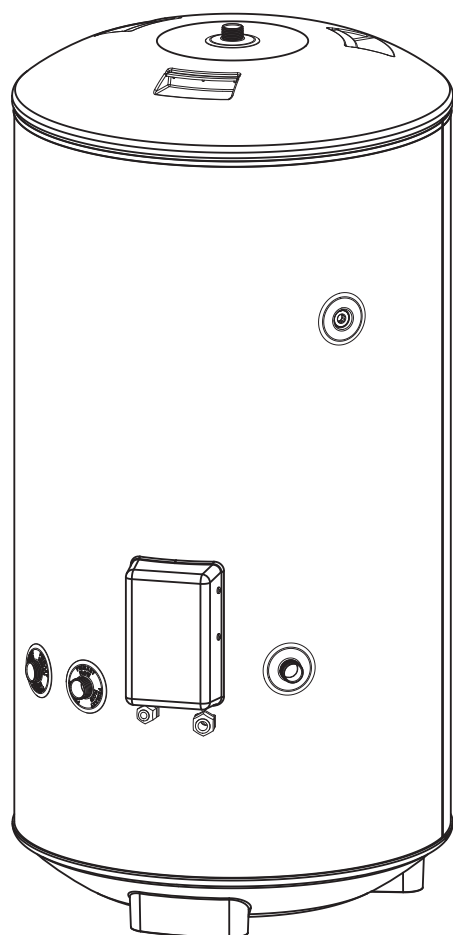

AIR TO WATER HEAT PUMP SYSTEM Installation manual

HOT WATER CYLINDER INDIRECT HEATING METHOD CLOSED OUTLET (UNVENTED)

150 litre	HWS-1501CSHM3-E
210 litre	HWS-2101CSHM3-E
300 litre	HWS-3001CSHM3-E



AIR TO WATER HEAT PUMP SYSTEM INSTALLATION AND SERVICE MANUAL	3	EN
SYSTÈME DE POMPE À CHALEUR AIR-EAU MANUEL D'INSTALLATION ET DE RÉPARATION	14	FR
LUFT-WASSER-WÄRMEPUMPENSYSYSTEM INSTALLATIONS - UND WARTUNGSANLEITUNG	26	DE
SYSTÉM TEPELNÉHO ČERPADLA (VZDUCH - VODA) SERVISNÍ A MONTÁŽNÍ MANUÁL	38	CZ
SUSTAV S TOPLINSKOM CRPKOM ZRAK-VODA PRIRUČNIK ZA UGRADNJU I SERVISIRANJE	49	CR
LEVEGŐ-VÍZ HŐSZIVATTYÚ RENDSZER FELSZERELÉSI ÉS SZERVIZELÉSI KÉZIKÖN	60	HU
ΣΥΣΤΗΜΑ ΑΝΤΛΙΑΣ ΘΕΡΜΑΝΣΗΣ ΑΕΡΑ - ΝΕΡΟΥ ΕΓΧΕΙΡΙΔΙΟ ΕΓΚΑΤΑΣΤΑΣΗΣ ΚΑΙ ΣΥΝΤΗΡΗΣΗΣ	72	GR
LUFT/VATTEN-VÄRMEPUMPSSYSTEM INSTALLATIONS- OCH SERVICEMANUAL	84	SV
LUFT-TIL-VANN VARMEPUMPESYSTEM INSTALLASJONS- OG VEDLIKEHOLDSHÅNDBOK	95	NO
SYSTÉM TEPELNÉHO ČERPADLA VZDUCH-VODA NÁVOD NA INŠTALÁCIU A OBSLUHU	106	SK
SISTEM TOPLOTNE ČRPALKE ZRAK-VODA PRIROČNIK ZA MONTAŽO IN VZDRŽEVANJE	118	SL



AIR TO WATER HEAT PUMP SYSTEM

HOT WATER CYLINDER INDIRECT HEATING METHOD CLOSED OUTLET (UNVENTED)

INSTALLATION AND SERVICE MANUAL

IMPORTANT

PLEASE READ AND UNDERSTAND THESE INSTRUCTIONS BEFORE INSTALLING THE WATER CYLINDER. INCORRECT INSTALLATION MAY INVALIDATE GUARANTEE. THE WATER CYLINDER MUST BE INSTALLED BY A QUALIFIED INSTALLER IN ACCORDANCE WITH LOCAL PLUMBING, BUILDING AND ELECTRICAL REGULATIONS. PLEASE LEAVE THIS MANUAL WITH THE UNIT FOR FUTURE REFERENCE.

EN

TECHNICAL SPECIFICATIONS

Rated pressure	1.0 MPa (10 bar)	
Test pressure (hydraulic)	1.5 MPa (15 bar)	
Minimum recommended supply pressure	0.1 MPa (1 bar)	
Max. primary circuit working pressure	0.35 MPa (3.5 bar)	
Electrical rating (cylinder heater)	2.75kW @ 230V~	
Weight (full)	150 litre indirect	181 kg
	210 litre indirect	251 kg
	300 litre indirect	360 kg

COMPONENTS SUPPLIED

- Water cylinder incorporating electric cylinder heater and thermal controls.
- Safety Group incorporating a Pressure Relief Valve, Check (Non-return) Valve and Isolating Valve.
- Compression nuts and olives.
- Cylinder heater key spanner.

1.0 IMPORTANT INSTALLATION POINTS

- 1.1 The unit, for use with the ESTIA air to water heat pump system, is a purpose designed unvented water cylinder.
- 1.2 The water cylinder **MUST** be fitted with a Pressure Relief Valve that complies with your local Plumbing and Building Regulations. **FAILURE TO PROVIDE ADEQUATE PRESSURE RELIEF WILL INVALIDATE ANY GUARANTEE AND LEAD TO A DANGEROUS INSTALLATION.**
- 1.3 Where the inlet pressure exceeds 0.6 MPa (6 bar) a Pressure Reducing Valve (set at max. 0.5 MPa (5 bar)) should be fitted to the inlet supply to the water cylinder. This **MUST NOT** be fitted between the Pressure Relief Valve and the water cylinder.
- 1.4 A Check (non-return) Valve should be fitted to the inlet supply to the water cylinder. This **MUST NOT** be fitted between the Pressure Relief Valve and the water cylinder.
- 1.5 This appliance is not intended for use by persons (including children) with reduced physical, sensory or mental capabilities, or lack of experience or knowledge, unless they have been given supervision or instruction concerning use of the appliance by a person responsible for their safety. Children should be supervised to ensure that they do not play with the appliance.

EN

2.0 INSTALLATION – GENERAL REQUIREMENTS

- 2.1 National Wiring Regulations may contain restrictions concerning the installation of these units in certain areas, eg. Bathrooms.
- 2.2 The unit **MUST** be installed vertically.
- 2.3 The unit must be positioned on a level surface.
- 2.4 Enough space should be left around the unit for pipe connections and for access to controls and any safety valves fitted. Refer to Diagram 1 and the Dimensions Table to determine a suitable position for the water cylinder.
- 2.5 **NOTE:** Ensure the floor can support the full weight of the unit (see **TECHNICAL SPECIFICATIONS**).
- 2.6 **DO NOT** install where the unit may freeze.
- 2.7 The mains water supply to the property will be supplying both the hot and cold water requirements simultaneously. It is recommended that the maximum water demand is assessed and the water supply checked to ensure this demand can be satisfactorily met.
NOTE: a high mains water pressure will not always guarantee high flow rates. We suggest the minimum supply requirements should be 0.1 MPa (1.0 bar) pressure and 20 litres per minute flowrate. However, at these values outlet flow rates may be poor if several outlets are used simultaneously. The higher the available pressure and flow rate the better the system performance.
- 2.8 **LIMITATIONS:**
The water cylinder should not be used in association with any of the following:
 - Situations where maintenance is likely to be neglected or safety devices tampered with.

- Water supplies that have either inadequate pressure or where the supply may be intermittent.
- Situations where it is not possible to safely pipe away any discharge from the safety valves.
- Areas where the water supply consistently contains a high proportion of solids or suspended matter unless adequate filtration can be ensured on the inlet water supply.

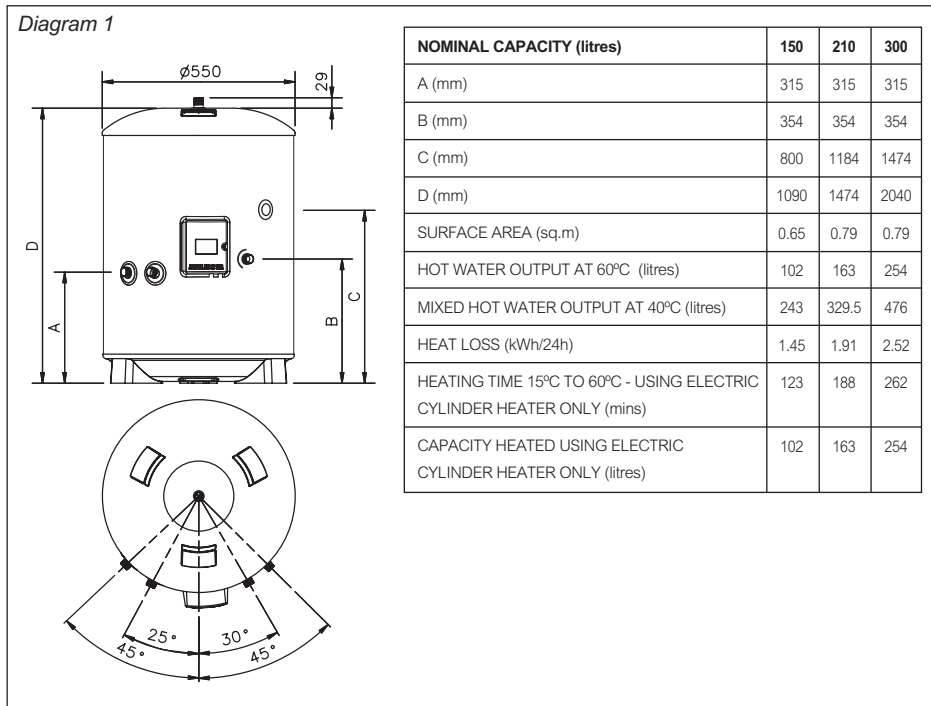

EN

3.0 INSTALLATION – PLUMBING

- 3.1 Refer to section **IMPORTANT INSTALLATION POINTS**. Plumb in valves in the sequence shown in Diagram 2. Ensure the valves are installed in the correct orientation by reference to the direction of flow arrows marked on them. The water cylinder **MUST** be fitted with a Pressure Relief Valve that complies with your local Plumbing and Building Regulations. (Safety Group supplied). **FAILURE TO PROVIDE ADEQUATE PRESSURE RELIEF WILL INVALIDATE ANY GUARANTEE AND LEAD TO A DANGEROUS INSTALLATION.** Any discharge pipe connected to the Pressure Relief device must be installed in a continuously downward direction in a frost free environment.
- 3.2 The water connections on the unit accept direct connection of 22mm outside diameter pipe; nuts and olives are supplied for this purpose. The thread on the connections is G3/4 to enable the use of G3/4 female connections to be used if required. **DO NOT** use zinc plated water pipes. When steel pipes are used the pipe should be insulated from the stainless steel vessel by using di-electric couplings.
- 3.3 The sanitary water **INLET** is marked **BLUE**, the **OUTLET** is marked **RED**. Several hot outlets can be served, however, individual site demands should be considered when choosing capacity and the number of outlets to be served.
- 3.4 It is recommended that an isolating valve is fitted on the cold water supply to the water cylinder.

- 3.5 A drain cock must be fitted below the water cylinder in the inlet pipework. It must be sited between the water cylinder and the Check Valve.
- 3.6 A sanitary circuit expansion vessel may be fitted to the cold water supply as shown in Diagram 2 to prevent wastage of expanded water. The following sizes are recommended:
- | | |
|-----------|-----------------|
| 150 litre | 12 litre vessel |
| 210 litre | 18 litre vessel |
| 300 litre | 24 litre vessel |
- 3.7 A re-circulation circuit can be installed on the sanitary water circuit. A connection is provided for the re-circulation circuit return pipe (threaded G3/4 female).
- 3.8 The primary heating circuit **MUST** be connected via the Hydro Unit. Refer to the Installation Instructions supplied with the Hydro Unit for full details.

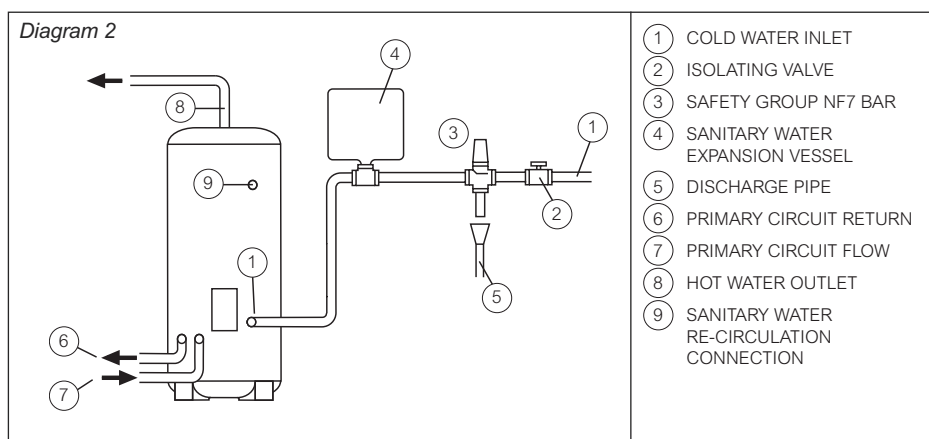

EN

4.0 ELECTRICAL REQUIREMENTS

- 4.1 The unit is supplied with a factory fitted cylinder heater complete with thermal sensor and over-temperature cut-out. The cylinder heater is rated 2.75kW at 230V~.
- 4.2 The cylinder heater is located behind the white terminal cover on the front of the unit. The cover is secured by 2 screws on each side of the cover and a threaded domed nut on the front of the cover. **ISOLATE THE ELECTRICAL SUPPLY BEFORE REMOVING THE COVER.**
- 4.3 The cylinder heater **MUST** be earthed.
- 4.4 All electrical wiring should be carried out by a competent electrician and be in accordance with the latest national Wiring Regulations. The circuit must be protected by a suitable fuse and double pole isolating switch with a contact separation of at least 3mm in both poles.
- 4.5 The cylinder heater should be wired in accordance with Diagram 3 and the Air to Water Heat Pump Installation Manual. The supply cable must be via the Heat Pump Controls Housing, direct connection to the mains electrical supply will invalidate the guarantee and may result in a dangerous installation. The supply cable must be routed through the right hand cable gland provided and the outer sheath of the cable firmly secured by tightening the screw on the cable gland. The recommended cable type is 2.5mm² 3 core heat resistant sheathed.
- 4.6 The thermal sensor should be connected to the Heat Pump Controls Housing in accordance with Diagram 3 and the Air to Water Heat Pump Installation Manual.

The cable to the thermal sensor must be routed through the left hand cable gland provided and the outer sheath of the cable firmly secured by tightening the screw on the cable gland. The sensor cable should be 0.75mm² 2 core + shield (ground) with a maximum current rating of 100mA. The cable should not be longer than 5 metres.

- 4.7 Replace the terminal cover before operating.
- 4.8 **DO NOT** heat the unit until the water cylinder has been completely filled with water.
- 4.9 Thermal control of the water cylinder is done by the Hydro Unit controls. Refer to the Air to Water Heat Pump Installation Manual for instructions for setting the hot water storage temperature.
- 4.10 The electrical supply from the Air to Water Heat Pump to the cylinder heater incorporates an over-temperature thermal cut-out that will switch off the cylinder heater in the event of a thermal control failure. **DO NOT** bypass the thermal cut-out in any circumstances.

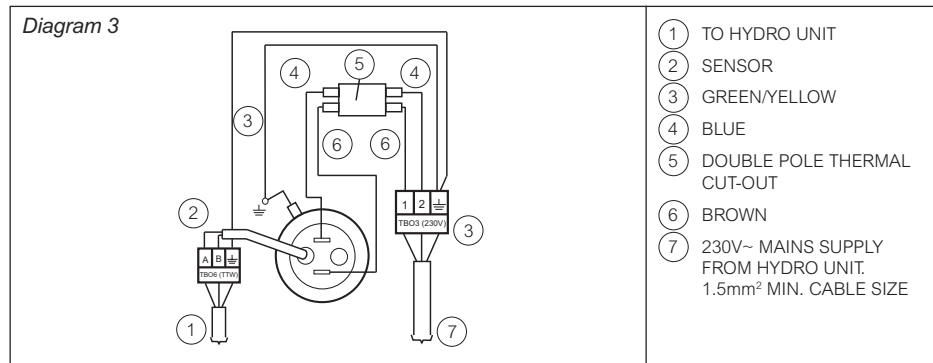

EN

5.0 COMMISSIONING

WARNING: Water that is left standing in a stainless steel water cylinder for long periods without draw off will become de-oxygenated and potentially corrode the vessel material. If the installation is to be left unused following installation and commissioning the water cylinder should be drained or regularly (once per week) flushed through with fresh mains water.

When placing the unit into service the procedure for filling the unit and the system checks detailed below should be repeated.

- 5.1 **DO NOT** switch on the Air to Water Heat Pump until the unit has been filled with water and checked for leaks.
- 5.2 Check that all installation, electrical and discharge pipe requirements have been met.
- 5.3 Check that all water and electrical connections are correctly made and are tight.
- 5.4 Open a hot tap supplied by the unit, turn on the cold water supply to the unit.
- 5.5 Allow the unit to fill and leave the hot tap running for a short while to purge any air and flush out the pipework. Close the hot tap.
- 5.6 Open successive hot taps to purge any air from the system.
- 5.7 With all hot taps closed, check the system for water leaks and rectify as necessary.

- 5.8 Manually test the operation of the Pressure Relief Valve. Ensure water flows freely from the valve and through the discharge pipe.
- 5.9 Fill the primary circuit following the “Water Pipe” section in the Hydro Unit Installation Manual. Vent any trapped air by opening the air bleed point or automatic air vent.
- 5.10 Switch on the electrical supply to the Air to Water Heat Pump and ensure the programmer is set to **HOT WATER** mode. Check that any motorised valves or primary pumps are working and allow the unit to heat. The hot water temperature may be varied using the Hydro Unit remote controller, for details refer to the Air to Water Heat Pump Owners Manual.

6.0 MAINTENANCE – DESCALING CYLINDER HEATER

- 6.1 Little maintenance is required, however in hard water areas the unit will require periodic descaling to ensure efficient operation. To descale the unit:
- 6.2 Switch off and disconnect the electrical supply and shut down the heat pump. Turn off the water supply to the unit.
- 6.3 Open a hot tap served by the unit to relieve any system pressure. Empty the unit by opening the drain valve in the inlet pipework.
- 6.4 Open the terminal cover. Carefully remove the thermal sensor from its pocket on the cylinder heater by pulling outwards.
- 6.5 Disconnect the link wires connecting the thermal cut-out to the cylinder heater. Carefully remove the thermal cut-out sensing bulb from its pocket on the cylinder heater by pulling outwards. Be careful not to kink the capillary tube.
- 6.6 Remove the element tail insulating shroud by pulling it outwards from the element.
- 6.7 Unscrew cylinder heater backnut. A key spanner is provided with the unit for easy removal/tightening of the cylinder heater backnut. Remove the cylinder heater from the unit. **NOTE** over time the cylinder heater gasket may become stuck to the mating surface, to break the seal insert a round bladed screwdriver into one of the pockets on the cylinder heater and gently lever up and down.
- 6.8 Carefully remove any scale from the surface of the element. **DO NOT** use a sharp implement as damage to the element surface could be caused.
- 6.9 Ensure sealing surfaces are clean and seals are undamaged. If in doubt fit a new gasket.
- 6.10 Replace cylinder heater ensuring the element tails are in the **VERTICAL** plane (see Diagram 3). Secure in place by re-fitting cylinder heater backnut and tightening. It may be helpful to support the cylinder heater using a round bladed screwdriver inserted into one of the element pockets whilst the backnut is being tightened.
- 6.11 Replace the element tail insulating shroud by carefully pushing over the element tails until it sits flush with the face of the element mounting plate.
- 6.12 Replace the thermal cut-out capillary in the **LEFT HAND** pocket of the cylinder heater. Ensure it is fully inserted and that the capillary tube is not kinked. Ensure the capillary tube is routed such that it does not come into contact with the element tails.

EN

- 6.13 Replace the thermal sensor into the **LEFT HAND** pocket of the cylinder heater behind the thermal cut-out. Ensure it is fully inserted, and the securing grommet is pushed into the open end of the pocket.
- 6.14 Refit the cylinder heater wiring links by inserting the male terminations into the female terminals on the element tails in accordance with Diagram 3. Check all wiring terminations are tight and secure. Replace and secure the terminal cover.
- 6.15 **DO NOT SWITCH ON EITHER THE AIR TO WATER HEAT PUMP OR CYLINDER HEATER UNTIL THE UNIT HAS BEEN RE-FILLED WITH WATER.** Re-commission the unit following the Installation and **COMMISSIONING** instructions.

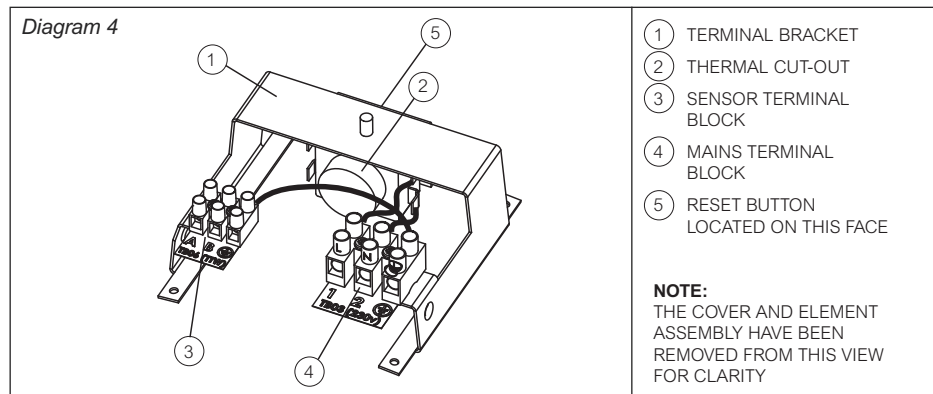

7.0 MAINTENANCE – SAFETY VALVES

EN

- 7.1 The Pressure Relief Valve and any other safety valves fitted should be regularly checked for correct operation.
- 7.2 Manually operate the valve(s) and ensure that water flows freely from the valve and through the discharge pipe. **NOTE:** the water discharged may be very hot. Ensure the valve re-seats correctly when released.

8.0 USER INSTRUCTIONS

- 8.1 The water storage temperature at the Air to Water Heat Pump System Water Cylinder is set at the control panel of the Hydro Unit. This can be set to give temperatures in the range of 40°C to 75°C, 60°C is recommended. Refer to the Hydro Unit Installation Manual for details of how to adjust the storage temperature should this be necessary.
- 8.2 To avoid any risk of freezing when the cylinder is not in use for long periods during the winter months, it is recommended that the Air to Water Heat Pump primary supply and the cylinder heater are switched off and the water cylinder is drained. **NOTE:** this will not protect other parts of the system pipework. If this is done the water cylinder must be fully re-commissioned prior to switching on the Air to Water Heat Pump and cylinder heater or damage may be caused.
- 8.3 To ensure the water cylinder continues to operate at its optimum performance it should periodically be maintained in accordance with the instructions given under the sections headed **MAINTENANCE**.

8.4 IMPORTANT NOTES TO THE USER

- Do not block or restrict the discharge from any safety valve fitted.
- Do not tamper with any safety valve fitted.
- Do not bypass the thermal cut-out in any circumstances.
- If a fault is suspected contact a qualified engineer to check the system.

9.0 SPARE PARTS

9.1 The following list of spare parts is available for the Air to Water Heat Pump water cylinder. Refer to the technical data label on the unit to identify the model installed and to ensure the correct parts are ordered.

9.2 **DO NOT** replace with parts not recommended by the manufacturer as this will invalidate your guarantee and may render the installation dangerous.

9.3	Description	Part No.
①	Cylinder heater	95:606:967
②	Cylinder heater gasket.....	95:611:012
③	Cylinder heater backnut.....	95:607:118
	Cylinder heater key spanner.....	95:607:119
⑤	Thermal cut-out (cylinder heater)	95:612:038
⑥	Element tail insulating shroud.....	95:607:115
⑦	Terminal cover	95:614:109
⑧	Terminal block (cylinder heater connection).....	95:607:113
⑨	Terminal block (thermal sensor connection).....	95:607:114
	Thermal sensor.....	95:612:037
	Set of compression nuts and olives.....	95:607:116
⑫	Secondary re-circulation connection plug	95:607:117
	Safety Group	95:605:073

EN

Diagram 5

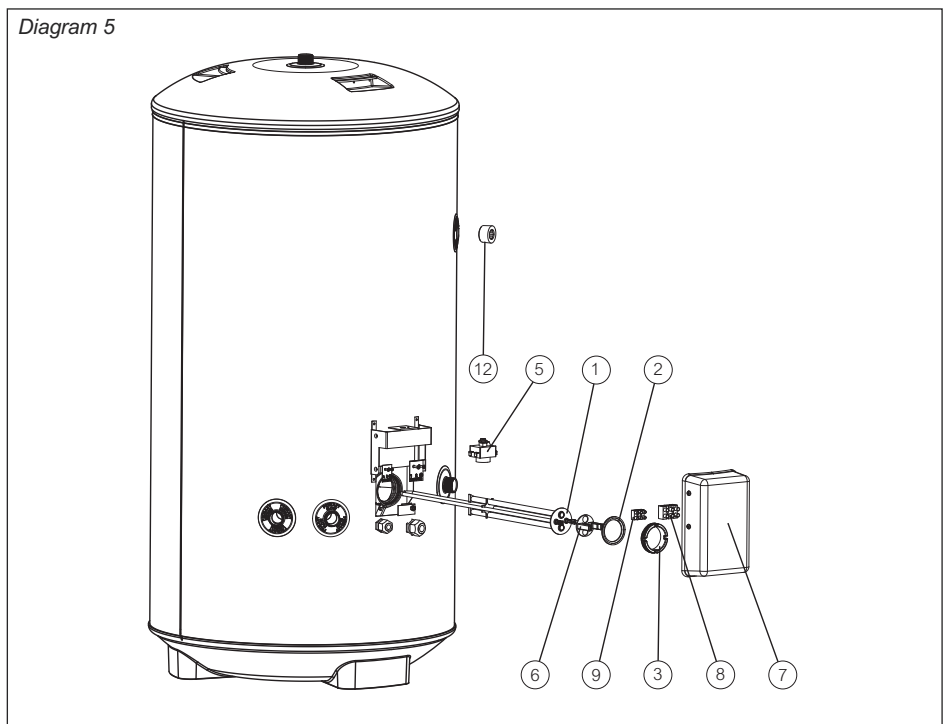

10.0 FAULT FINDING

The table below lists some common faults, their possible causes and their remedy. Any servicing of the water cylinder and Air to Water Heat Pump system must be carried out by a trained competent installer.

FAULT	POSSIBLE CAUSE	REMEDY
No hot water flow	1. Mains water supply off	1. Check and turn on mains water supply
	2. Mains water filter (if fitted) blocked	2. Turn off water supply. Remove filter and clean in accordance with manufacturers instructions
	3. Inlet water control valves incorrectly fitted	3. Check and refit as required
Water from hot taps is cold	1. Controller on Heat Pump Hydro Unit set to Space Heating only	1. Check setting
	2. Heat Pump not working	2. Check operation of Heat Pump. If a fault is suspected consult the Heat Pump Manual
	3. Faulty water cylinder temperature sensor	3. Check sensor operation. Replace if necessary
Water from hot taps is only warm	1. Cylinder heater thermal cut-out has operated	1. Check. Reset by pushing button on cut-out
	2. Faulty water cylinder temperature sensor	2. Check sensor operation. Replace if necessary
Water from hot taps is too hot	1. Water storage temperature on Heat Pump Controller is set too high	1. Check and adjust as required
	2. Faulty water cylinder temperature sensor	2. Check sensor operation. Replace if necessary
Water discharges from Pressure Relief Valve continually	1. Mains water pressure too high	1. Refer to section Important Installation Points for correct pressure. If necessary fit a Pressure Reducing Valve to inlet water supply
	2. Pressure Relief Valve seat is damaged	2. Remove and replace

EN

11.0 GUARANTEE

For warranty details please contact your ESTIA Heat Pump supplier.

This water cylinder is guaranteed provided that:

- 11.1 The unit has been installed in accordance with these instructions and all necessary inlet controls and safety valves have been fitted correctly.
- 11.2 Any valves or controls are of the manufacturers recommended type.
- 11.3 The unit has not been tampered with and has been regularly maintained as detailed in these instructions.
- 11.4 The unit has been used only for heating potable water (max. 250mg/l chloride).
- 11.5 The unit has not been subjected to high chloride levels in the water supply or incorrect disinfection methods.
- 11.6 Following commissioning the unit is put into service within a period of 7 days. If this is not the case it must either be drained or regularly flushed as required in the section "Commissioning – Warning".
- 11.7 The unit is **NOT** guaranteed against damage by frost or due to build up of scale.
- 11.8 This guarantee does not affect the statutory rights of the consumer.

This guarantee **DOES NOT** cover the ESTIA Air to Water Heat Pump Outdoor Unit or ESTIA Hydro Unit.

EN

12.0 ENVIRONMENTAL INFORMATION

- 12.1 This product is manufactured from many recyclable materials. At the end of its useful life it should be disposed of at a Local Authority Recycling Centre to realise the full environmental benefits.
- 12.2 The insulation material is CFC/HCFC free expanded polyurethane foam with an ozone depletion factor of zero.

The pace of product development is such that we reserve the right to change product specifications without notice. We do, however, strive to ensure that all information in this leaflet is accurate at the time of publication.

IMPORTANT INFORMATION AND WARNING

READ BEFORE INSTALLING THE UNIT. KEEP IN A SAFE PLACE. THE INFORMATION IN THE FOLLOWING NOTES IS NEEDED FOR THE END OF LIFE DISPOSAL OR REUSE OF THE UNIT.

- We are very sensitive to the environment and welcome the 2002/96/EC WEEE (Waste Electrical and Electronic Equipment) Directive.
- This product is compliant with EU Directive 2002/96/EC. It must be collected separately after its use is completed and must not be disposed of as unsorted municipal waste.
- The objectives of the EU Directive 2002/96/EC are to tackle the fast increasing waste stream of electrical and electronic equipment, increase the recycling of electric and electronic equipment (“EEE”), and to limit the total quantity of waste EEE (“WEEE”) going to disposal.
- The crossed out wheeled bin symbol that is affixed to the product indicates that this product may fall under the Directive.
- The user is responsible for returning the product to the appropriate collection facility as specified by your municipality or the distributor. In case of installation of a new product, it may be possible to have the distributor pick up old WEEE directly.
- The producer, importer and distributor are responsible for collection and treatment of WEEE, either directly or through a collective system. The distributor for your country is shown below.
- In case of violation of the Directive, sanctions are set in each country.
- We are in general following the CECED interpretation which considers the WEEE Directive applicable to Portable units, De-humidifiers, WRACs (Window Room Air to Water Heat Pumps), Split systems up to 12kW, plug in refrigerators and freezers.
- Nevertheless, there may be differences among various member state laws. In cases where national laws exclude some products from the WEEE scope, those laws must be followed. In countries where these products are not covered by the WEEE scope the WEEE obligations do not have to be followed.
- The WEEE Directive does not apply to products sold outside the European Community. In these cases the WEEE obligations do not have to be followed, however compliance with any local regulations must be ensured.
- For additional information please contact the municipal facility, the shop/dealer/distributor/installer that has sold the product, or the producer.

EN